

ID-Nr. 32910-041
Model FX90.229.090.WDAC

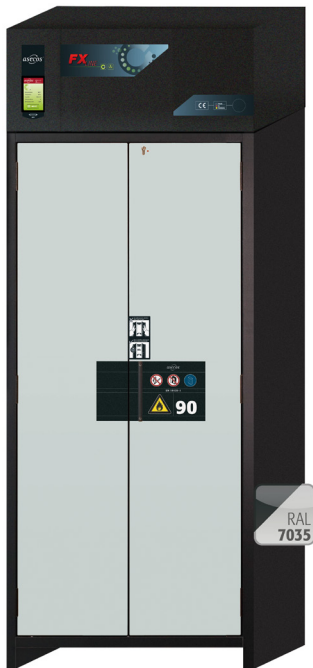

Recirculating air filter storage cabinet FX-PEGASUS-90 Model FX90.229.090.WDAC, body colour anthracite grey (RAL 7016), with wing doors in light grey (RAL 7035)

Safe and approved storage of flammable liquids and further hazardous substances

Function / construction:

Cabinet body

- **Robust construction and longevity:** triple hinged door, safety elements assembled outside the storage compartment for increased protection against corrosion, scratch- and impact-resistant surface, easy to clean
- **Effortless use:** one-hand operation for double-door cabinets (AGT)
- **User-friendly and safe:** door open arrest system (standard), convenient and safe removal or storage of containers
- **Always closed:** serial automatic door closing (TSA) releases arrested doors after approx. 60 seconds; acoustic and visual signal before closing
- **No unauthorised use:** doors lockable with cylinder locking (integration in an existing locking system possible) and locking state indicator (red/green)
- **Easy transport:** integrated transport base with removable, optional base cover
- **Easy alignment:** adjusting aids to compensate for uneven floor

Recirculating air filter system

- Ideal for the direct installation in working areas – very low noise, only approx. 39 dB (A)
- With multi-stage wideband filter
- Monitoring electronics for extraction and filtration incl. cool-device cable and power plug
- Optical and acoustical alarm including potential-free alarm contact
- Display with innovative touch panel
- ATEX compliant: **CE** II 3/-G Ex ic nA IIB T4 Gc

Dimensions	
Width (external)	893.00 mm
Depth (external)	615.00 mm
Height (external)	2294.00 mm
Width (internal)	750.00 mm
Depth (internal)	522.00 mm
Height (internal)	1647.00 mm

The available internal dimensions can vary depending on the interior equipment package.

Weight / Load	
Weight without interior equipment	370 kg
Distributed load	667.00 kg/m ²
Maximum load	600 kg

Electrical component	
Frequency	50 Hz
Nominal voltage	230 V
Maximum current consumption	0.5 A
Power consumption in operation	120 W
Power consumption in standby mode	50 W

Colouring / Surface finish	
Body colour code	RAL 7016
Body colour	anthracite grey
Body surface finish	textured
Door / Drawer colour code	RAL 7035
Door / Drawer colour	light grey
Door / Drawer surface finish	textured

General Information	
Number of doors	2
Door opening angle	89.50°
Depth with open doors	1015 mm
Customs tariff number	94032080

Front view

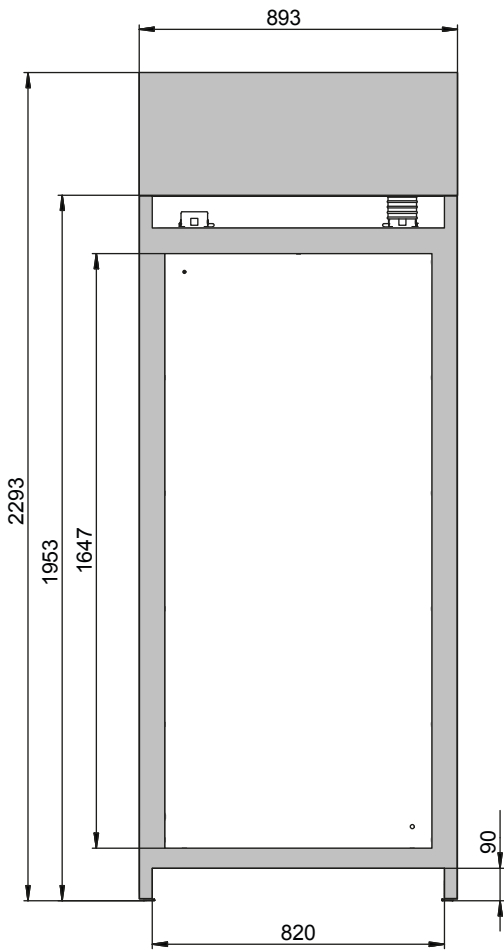

Side view

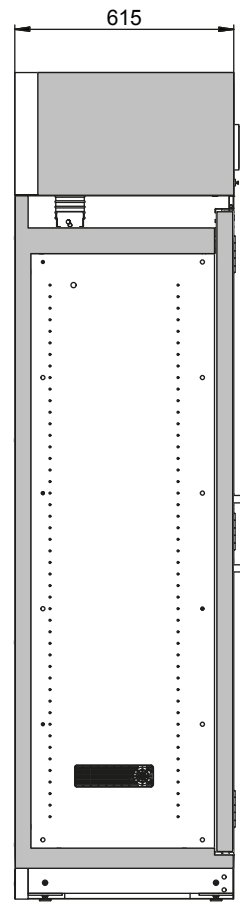

Top view

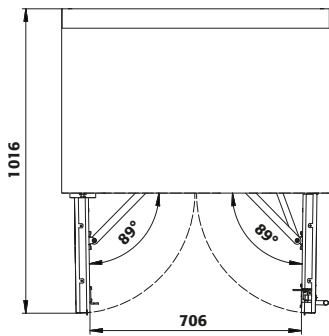

For further information please visit www.asecos.com